

Mounting Dimensions

Contact Us

3:1 – 25:1

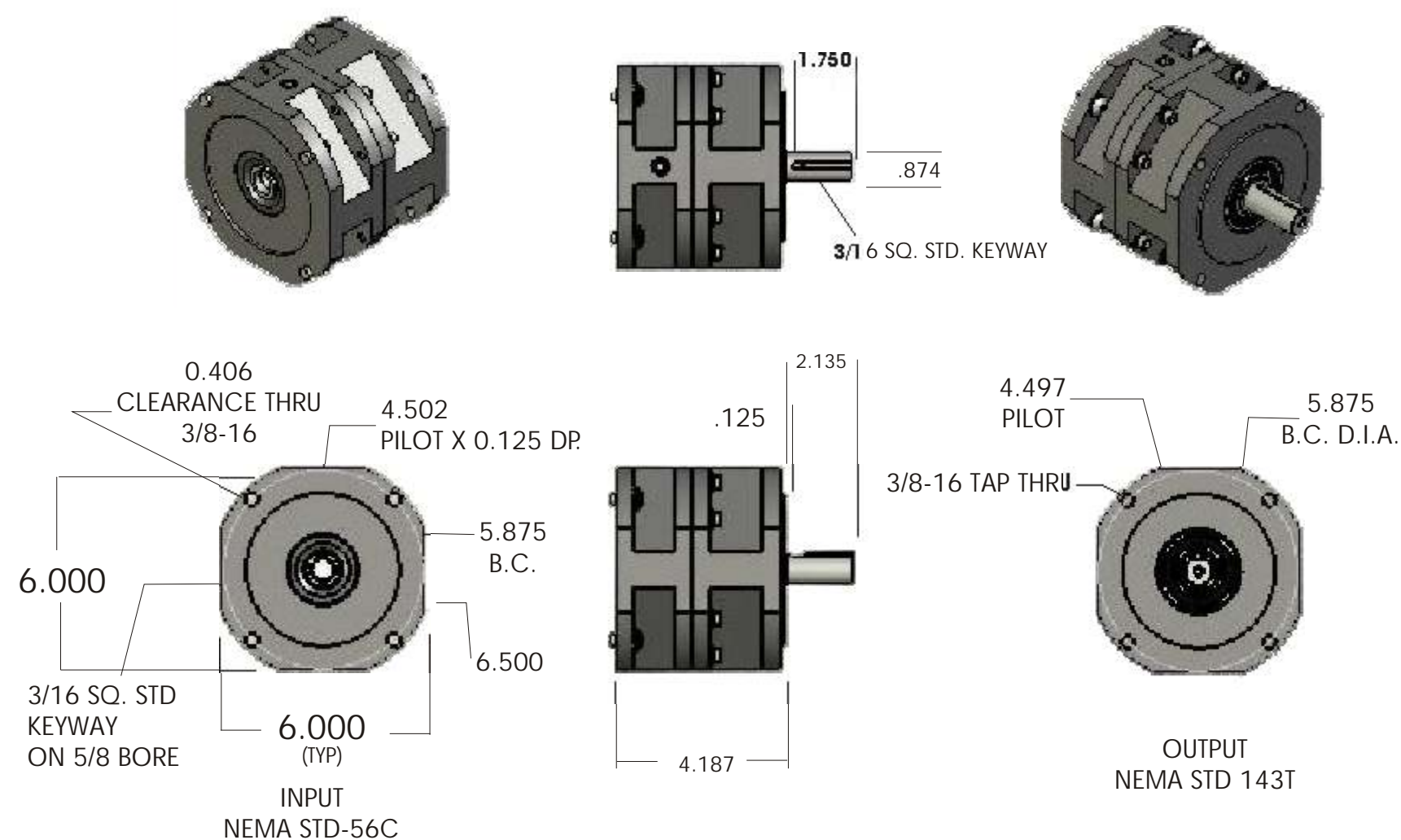

45:1 – 125:1

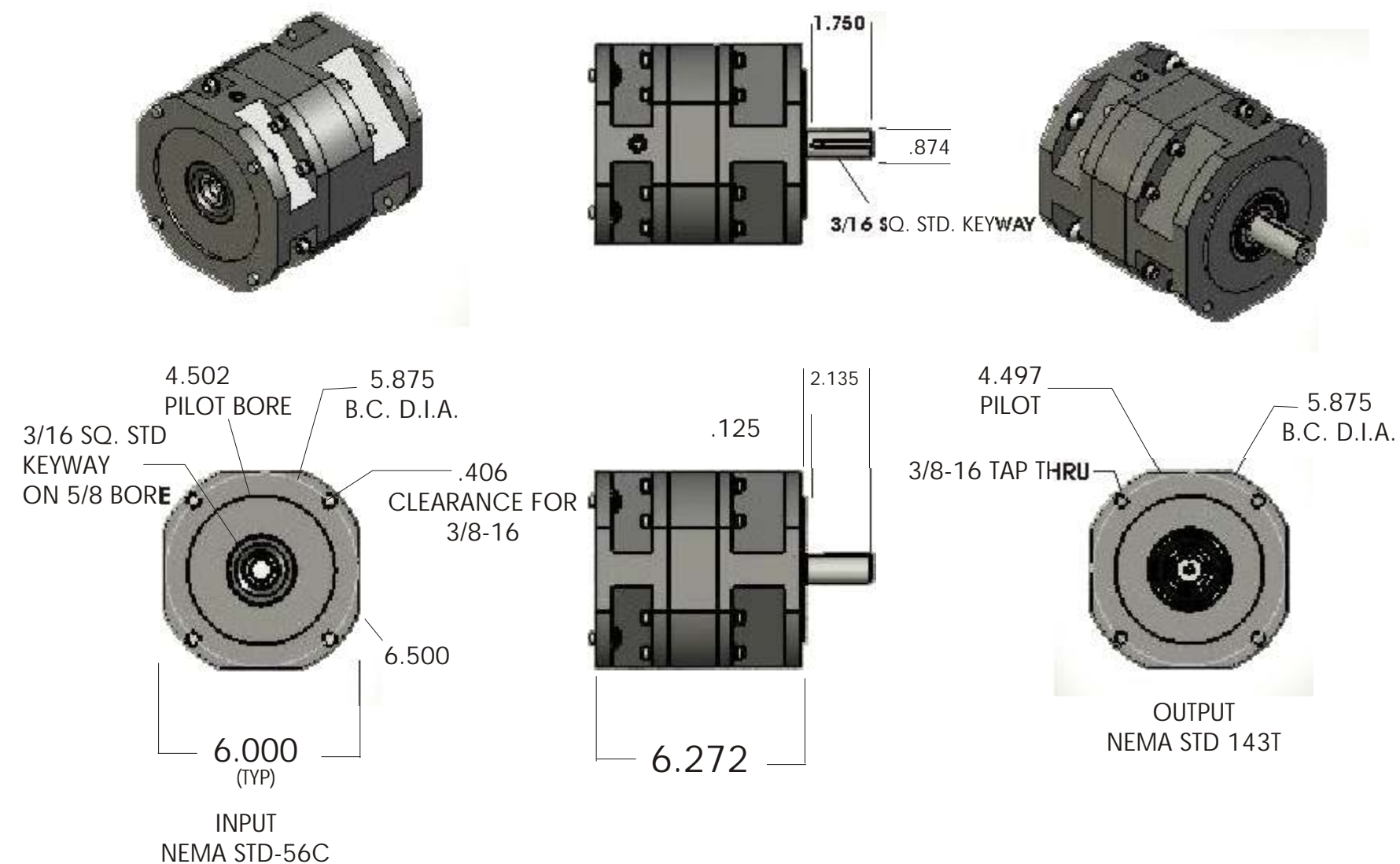

Specifications

| Model Type | Reduction Ratio | Output Torque (in-lbf) | Power Rating (HP) | Efficiency (%) | Noise (DBA) | Backlash (arc-min) | Weight (lbs) |
|------------|-----------------|------------------------|-------------------|----------------|-------------|--------------------|--------------|
| GHP20-3 | 3:1 | 375 | 2.5 | 0.93 | 72 | 20 | 12.0 |
| GHP20-4 | 4:1 | 400 | 2.5 | 0.93 | 72 | 20 | 12.0 |
| GHP20-5 | 5:1 | 425 | 2.5 | 0.93 | 72 | 20 | 12.0 |
| GHP20-9 | 9:1 | 450 | 2.5 | 0.86 | 72 | 40 | 14.2 |
| GHP20-12 | 12:1 | 475 | 1.8 | 0.86 | 72 | 40 | 14.2 |
| GHP20-17 | 17:1 | 500 | 1.3 | 0.86 | 72 | 40 | 14.0 |
| GHP20-25 | 25:1 | 570 | 1.0 | 0.86 | 72 | 40 | 14.0 |

| Model Type | Reduction Ratio | Output Torque (in-lbf) | Power Rating (HP) | Efficiency (%) | Noise (DBA) | Backlash (arc-min) | Weight (lbs) |
|------------|-----------------|------------------------|-------------------|----------------|-------------|--------------------|--------------|
| GHP20-45 | 45:1 | 600 | 0.5 | 0.80 | 72 | 60 | 19.2 |
| GHP20-51 | 51:1 | 601 | 0.4 | 0.80 | 72 | 60 | 19.7 |
| GHP20-60 | 60:1 | 650 | 0.4 | 0.80 | 72 | 60 | 19.2 |
| GHP20-85 | 85:1 | 700 | 0.3 | 0.80 | 72 | 60 | 19.0 |
| GHP20-125 | 125:1 | 750 | 0.3 | 0.80 | 72 | 60 | 19.0 |

